

BOX Wi-Fi

Product part number: 90-60-508-002



USER MANUAL AND INSTALLATION GUIDE



1. INTRODUCTION	3
2. NMEA INPUT	3
3. WIRED NMEA OUTPUT	5
4. WI-FI CONNECTION	7
5. STATUS INDICATORS	7
6. USING THE « INIT » KEY	8
7. INSTALLATION	9
LIST OF ACCESSORIES	9
BEFORE INSTALLATION.....	9
MOUNTING THE <i>Box WiFi</i>	9
CONNECTION TO THE <i>TOPLINE BUS</i>	9
<i>NMEA INPUT SETUP</i>	10
SETUP PROCEDURE	11
8. SET A WIFI CONNECTION TO A SMARTPHONE	11
9. TECHNICAL SPECIFICATIONS	13
10. DIAGRAMME DE FLUX	14



1. INTRODUCTION

The **nke Box Wi-Fi** allows data to be exchanged between the Topline bus and wireless peripheral equipment such as smartphones, tablets and PCs.

It features a NMEA 183 input to receive AIS data **or** other data coming from a NMEA 183 compatible instrument and a NMEA 183 output wire.

It works as a multiplexer, combining AIS data with the Topline bus data to send them over the **Wi-Fi** link and the NMEA 183 wired output.

New channels can be created on the Topline bus once the NMEA 183 input has been set up with data coming from auxiliary NMEA 183 sources.

2. NMEA INPUT

The **nke Wifi Box** can process NMEA data format through the wire input and/or Wifi wireless connection.

The **nke Box Wi-Fi** identifies the sentences coming from an AIS receiver or any NMEA 183 source.

An auto baud rate detection algorithm allows reception of AIS and NMEA data at 4800, 9600, 19200, or 38400 bauds. The baud rate is saved in the memory once 10 correct NMEA sentences have been received.

The AIS data flow received via the NMEA input is sent directly to the **Wifi** connection and the NMEA 183 output.

Data coming from the NMEA 183 device is sent once the set up procedure has been completed on the Topline bus.



WARNING

Topline channels have priority: a NMEA 183 channel is not considered if an equivalent channel is already available on the Topline bus.

Once the instrument connected to the NMEA 183 input stops transmitting data the last values are displayed for 64 seconds on the Topline screens.

The NMEA input has **priority** on the Wifi NMEA connection.

Created channels		NMEA sentences used		
N°	Label	Priority 1	Priority 2	Priority 3
1	F_SPEEDO	VHW	--	--
2	HEADING MAGNETIC	HDG	VHW	HDM
3	HEADING TRUE	HDT	VHW	--
4	DEPTH	DPT	DBT	--

5	MINSEC	ZDA	RMC	--
6	TOTAL LOG	VLW	--	--
7	TRIP LOG	VLW	--	--
8	HOURS DAY	ZDA	RMC	--
9	AIR TEMPERATURE	MTA	XDR	--
10	WATER TEMPERATURE	MTW	--	--
11	BAROMETER	MMB	XDR	--
12	SPEEDO	VHW	--	--
13	APPARENT WIND SPEED	MWV	VWR	--
14	APPARENT WIND ANGLE	MWV	VWR	--
15	DISTANCE TO WPT	BWC	RMB	--
16	BEARING TO WPT (True)	BWC	RMB	--
17	CROSS TRACK ERROR	APB	RMB	XTE
18	SPEED OVER GROUND	VTG	RMC	--
19	COURSE OVER GROUND (True)	VTG	RMC	--
20	FORESTAY LOAD	XDR	--	--
21	BEARING ORIGIN TO DESTINATION	APA	APB	--
22	B_PILOT	APA	APB	XTE
23	YEAR MONTH	ZDA	RMC	--
24	F_HEADING	HDG	VHW	HDM
25	F_APPARENT WIND ANGLE	MWV	VWR	--
26	LAT_DEGMIN	GGA	GLL	RMC
27	LAT_MILMIN	GGA	GLL	RMC
28	LON_DEGMIN	GGA	GLL	RMC
29	LON_MILMIN	GGA	GLL	RMC
30	SPEED TO WP	WCV	--	--
31	TARGET SPEED	KEP	--	--
32	NEXT TACK HEADING	KEP	--	--
33	OPTIMUM TWA	KEP	--	--
34	TARGET VMG	KEP	--	--
35	POLAR SPEED	KEP	--	--
36	CMG OPTIMUM ANGLE	KEP	--	--
37	VMG OPTIMUM ANGLE	KEP	--	--
38	TARGET CMG	KEP	--	--
39	TARGET VMG	KEP	--	--

40	CURRENT DIRECTION	KEP	VDR	--
41	CURRENT SPEED	KEP	VDR	--
42	ATMOSPHERIC PRESSURE	MMB	XDR	--
43	DECLINAISON	RMC	--	--
44	WAYPOINT IDENTIFICATION	RMB	BWC	--
45	DYNAMICS1	PNKEA,,1	--	--
46	DYNAMICS2	PNKEA,,2	--	--
47	DYNAMICS3	PNKEA,,3	--	--
48	DYNAMICS4	PNKEA,,4	--	--
49	DYNAMICS5	PNKEA,,5	--	--
50	DYNAMICS6	PNKEA,,6	--	--
51	DYNAMICS7	PNKEA,,7	--	--
52	DYNAMICS8	PNKEA,,8	--	--

3. WIRED NMEA OUTPUT

The NMEA 183 wired output is set to 38400 bauds and sends AIS data from the NMEA 183 input and Topline data converted to NMEA standard sentences to instruments from other manufacturers.

The following data is converted and sent via NMEA 183, depending on the relevant sensors being connected to the **TOPLINE** bus:

Canaux Topline	XDR	RSA	DBT	DPT	VLW	VHW	MWV	VWR	VWT	MWD	MTW	MMB	HDG	HDM	HDT	VTG	ZDA	GLL	XTE	RMB	PNKEP.01	PNKEP.02	PNKEP.03	PNKEP.04	PNKEP.05	CUR	WPL
MAST ANGLE	X																										
RUDDER ANGLE		X																									
DEPHT			X	X																							
TRIP LOG					X																						
TOTAL LOG					X																						
SPEEDO						X																					
MAGNETIC HEADING						X																					
TRUE HEADING						X																					
CORRECTED AWA MAST ANGLE							X	X																			
AWA							X	X																			
AWS							X	X																			
TWA							X		X																		

4. WI-FI CONNECTION

The **WiFi** transmits the AIS data and the NMEA sentences coming from the NMEA input as well as the NMEA data from the Topline bus. It can also forward NMEA data (i.e. bearing and distance to waypoint) to the Topline bus (providing the relevant channels are available) and to the NMEA output.

The **nke Box Wi-Fi** creates a wireless access point 802.11b+g with the following parameters:

- SSID : NKE-xxxxxx
- WPA : 21xxxxxxxxxxx (matching the serial number featured on the **WiFi Box** label stuck on the side of the box)
- IP address: 192.168.56.1
- Port : 50000
- TCP + UDP protocol

TCP is a communication protocol which is based on connection with delivery validation and limits the use to one only host while UDP uses a simple transmission model allowing communication with several hosts simultaneously.







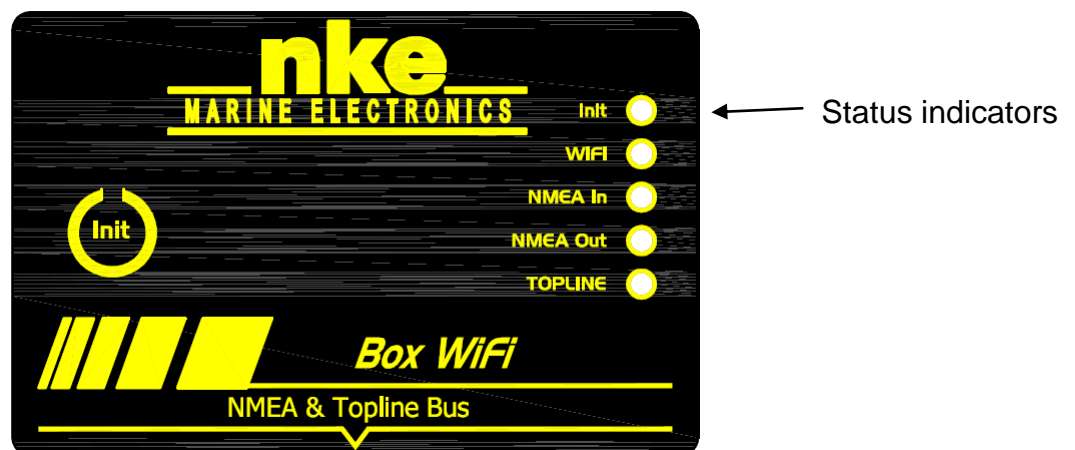



A DHCP server can connect up to 7 hosts simultaneously.

Data transmitted in NMEA 0183 format is identical to the data output via the wire interface (see §3).

5. STATUS INDICATORS



5 status indicators show the operation status of the **Box Wi-Fi**.

Init	 	Press the Init key Key press acknowledgement, audible signal
Wi-Fi	 	Wifi transmit Wifi reception
NMEA In	 	Off: no data coming in the NMEA port Flashes after each valid NMEA sentence received Flashes after each non-valid NMEA sentence received
NMEA Out		Flashes after each valid NMEA sentence sent on the wired NMEA port
TOPLINE	   	Flashes quickly if its Topline address is $\neq 0$ Flashes quickly if its Topline address is 0 Fix light: data bus Topline wire is disconnected or «no master » Flashes every second: interface's address is 0 and data bus Topline wire is disconnected or «no master »

6. USING THE « INIT » KEY

- Press and hold 1 sec to display the number of connected devices, up to 5. 1 device is indicated by the « Topline » led lighting red, 2 devices by the « Topline » and « NMEA Out », 3 devices by the « Topline + NMEA Out + NMEA In », 4 devices by « Topline + NMEA Out + NMEA In + Wifi » and 5 devices by all led indicators in red.
- Press and hold 3 sec followed by OFF and ON to reset all NMEA interfaces.
- Press and hold 3 sec will initialise the NMEA input (wire and WiFi), listen to NMEA sentences for 10 seconds, and then create list and nodes for the Topline bus (only slave).
- Press and hold 6 sec will launch a second NMEA initialisation, and add NMEA channels without overwriting the existing table. With this function, you can add NMEA channels coming from the WiFi connection without editing the configuration of the wired NMEA input.
- Press and hold 9 sec to perform a full reset and return to factory settings.

7. INSTALLATION

List of accessories

- TOPLINE junction box with NMEA connection: 90-60-417

Before installation

The **Box WiFi** is protected from water splashing. It must be mounted in a location where there is no risk of submersion.

Mounting the **Box WiFi**

- Use Ø4mm screws

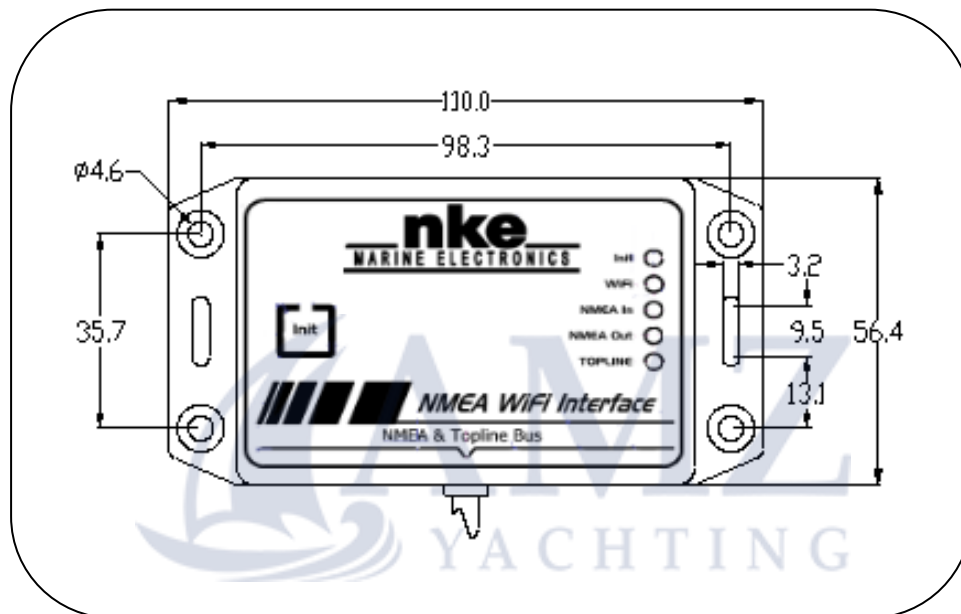

WARNING:

- The connection of the **nke Box Wi-Fi** must be carried out before power to the unit is switched on.

Connection to the **Topline Bus**

1. Run the **nke Box Wi-Fi** cable to the **TOPLINE** junction box in your system.
2. Connect the bus cable in the junction box.
3. Connect the NMEA+ and NMEA- wires to your NMEA 183 device or AIS receiver.

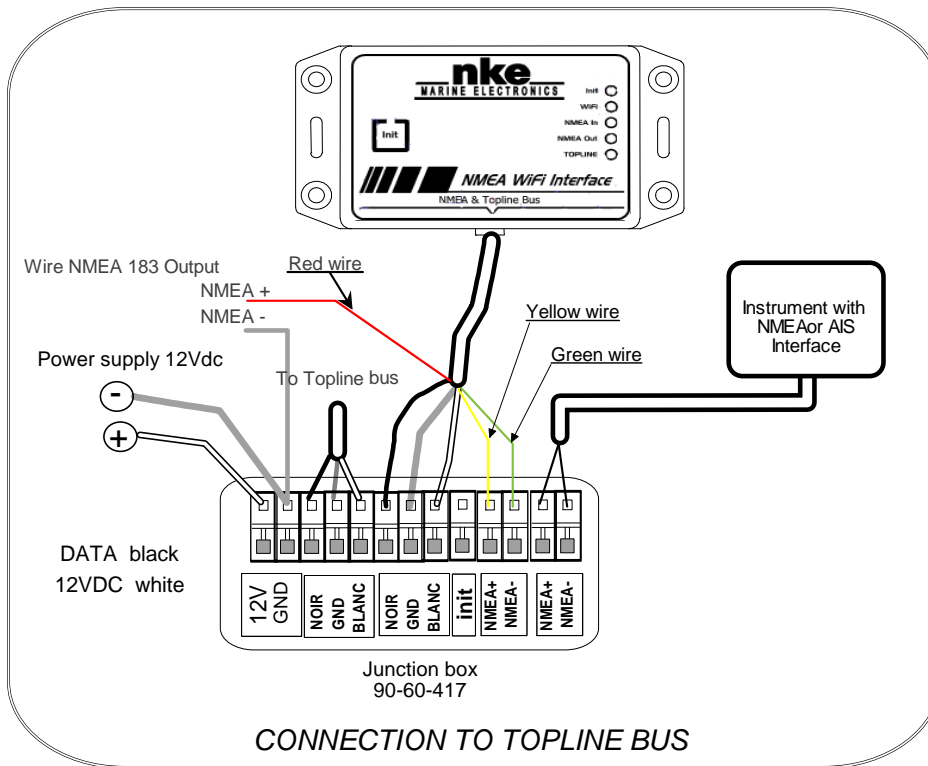

Should you need to shorten the bus cable, uncover and tin the wires before connecting in the junction box.

Wire colour codes

5 wire white cable	Identification	
white	+12V	TOPLINE bus
black	Data <i>Topline</i>	
braid	ground	
red	NMEA output	
yellow	NMEA +	NMEA input
green	NMEA -	

NMEA input setup



WARNING

The NMEA data coming from an AIS receiver does not need NMEA input calibration. It will be directly echoed on the Wi-Fi and wired NMEA outputs.

The **NMEA input** must be set-up to identify and save the NMEA sentences received from the connected instruments (GPS, PC, etc...). NMEA channels are created and

saved in the **nke Box Wi-Fi** memory. They will remain on the **Topline** bus each time the system is turned on.

Setup procedure

- Ensure that the NMEA 183 connected instrument sends data and press **INIT** until you hear 3 beeps.
- The NMEA 183 input port will scan for NMEA 183 data. This is acknowledged by audible signals over 10 seconds and a long signal once the scan is completed.
- Once the scan search is completed the unit will sound one signal per channel which has been created on the Topline bus.



WARNING

If there is no NMEA data coming in, this procedure gives a slave address to the **nke Box Wi-Fi**. In this case, the Interface is considered as a slave unit by the “master” display.

8. SET A WIFI CONNECTION TO A SMARTPHONE

Connect the device to the **WiFi Box** network and use the data coming from your Topline bus.

Activate the WiFi function on your Smartphone:

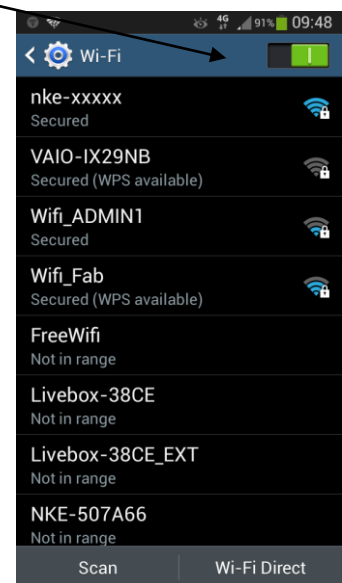

Select the **WiFi Box** network (see SSID indicated on the **WiFi Box** label) through the list of available WiFi detected.

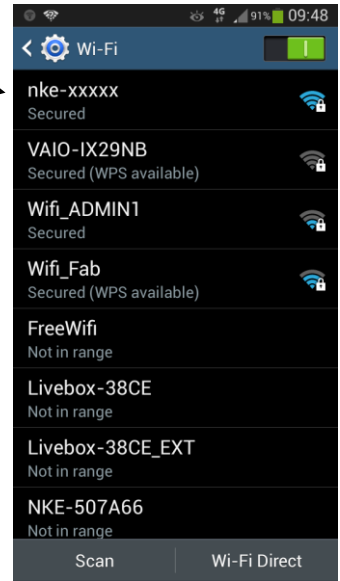

Type in the password (WPA indicated on the **WiFi Box** label) and press “Connect”



Set the application you want to use (“nke Display” in this example) with the **WiFi Box** IP address “192.168.56.1”, Port “50000” and the protocol “UDP or TCP”

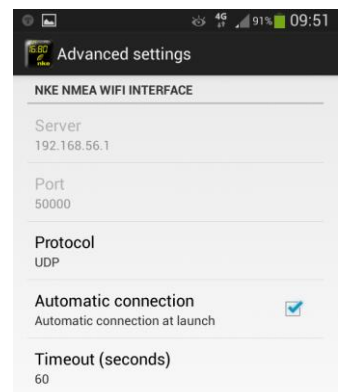

 **WARNING**
If your device is using a firewall, check and make sure “Port 50000” is available.

9. TECHNICAL SPECIFICATIONS

Description	Values
Dimensions	110x56.4x26mm (length x height x depth)
Weight	20g with a 3m cable (32g/m)
Power supply	8V – 32V DC
Current consumption at 12V	50 mA
NMEA input	NMEA 183, automatic baud rate configuration from 4800 to 38400 bauds. Direct reading of AIS data without input setup.
NMEA wired output	NMEA 183 38400 bauds
Wi-Fi connection	Wi-Fi 802.11b+g SSID:NKE-xxxxxx IP address: 192.168.56.1 Port: 50000 Protocol: TCP + UDP
Environment	IP54 protection (against dust and water splashing) Storage temperature: -20°C to +60°C Operating temperature: -10°C to +50°C
Power cable	Ø5,5mm, 4 wires + ground, 3m long.

10. DIAGRAMME DE FLUX

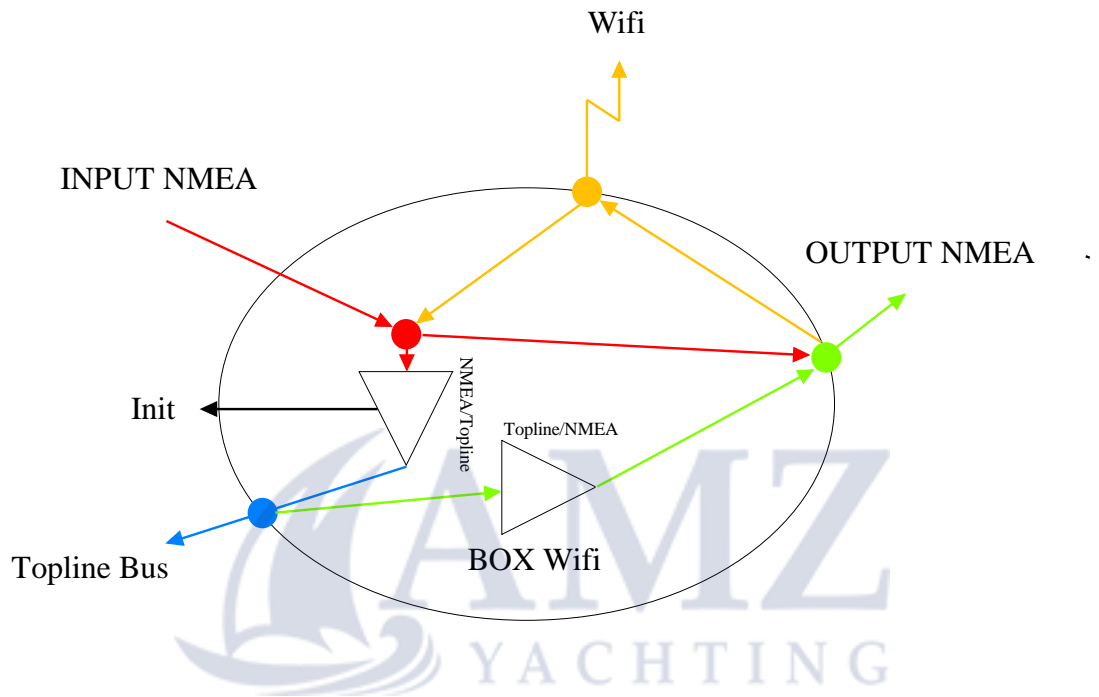

Déclaration de conformité

Nous,

Nke marine electronics
rue Gutenberg
ZI de Kerandré
56700 HENNEBONT
Tel : +33 297 365 685
Fax ; +33 297 364 674

Déclarons sous notre seule responsabilité que le produit

BOX WiFi

Auquel se réfère cette déclaration est en conformité avec les spécifications suivantes :

Safety : EN 60950-1 :2006+A11 :2009+A1 :2010
Health: EN 50371 :2002-03
EMC : EN 301 489-1 V1.8.1 :2008-04, EN 301 489-17 V2.1.1 :2009-05
Radio : EN 300 328 V1.7.1 :2006-10
FCC Part 15C, FCC id : T9J-RN171
IC : RSS-210

Le produit est conforme aux exigences de la directive CEM 89/336/CEE et porte en conséquence le marquage CE.

Hennebont

Jean Claude LE BLEIS



Cet appareil est conforme à la partie 15 des règles de la FCC. Son fonctionnement est soumis aux conditions suivantes : (1) ce dispositif ne peut pas causer d'interférences nuisibles, et (2) cet appareil doit accepter toute interférence reçue, y compris les interférences qui peuvent provoquer un fonctionnement indésirable.

CE0681 **FC**